

MP3

2026 Mediakit

MAGAZINE
MacPlas, the most read in Italy
mailed to 7,000 companies

WEBSITE
MacPlas Online, e-magazine
for the global plastics
and rubber industry
- News and classified ads
- Trade shows and sectoral events
- Banner ads

NEWSLETTER
MacPlas E-News, reaching
over 30,000 specialized
players worldwide,
both in Italian and
English editions
For a free subscription click on
www.macplas.it



Associated with:



In 2025 the average circulation of each issue of MacPlas was about 7,000 copies.

The technical magazine MacPlas is distributed to companies operating in different segments of the plastics and rubber industry. The circulation for each issue of the Italian edition, on the basis of readers' activity, is the following:

Italian plastics and rubber processors and recyclers (injection moulding and related processes 52%, extrusion 31%, blow moulding 5%, thermoforming 5%, others 7%)	5,500
Manufacturers and representatives of machinery & equipment (including Amaplast Members)	700
Producers of raw materials and additives	300
Others (retailers, agents etc.)	300
Abroad (chambers of commerce, associations etc.).	200
Total average circulation	7,000

MACPLAS INTERNATIONAL

Some special supplements (in local language) are scheduled concurrently with the most important specialized fairs worldwide, that often host collective participations of Italian exhibitors.



2026 ADVERTISING RATES

SIZES (full color)	EURO (VAT excluded)
Cover: 210x183 mm + 3 mm bleed on each side	3000
Full colour, bleed (210x297 mm + 3 mm oversize for each side)	1,300
1/2 page, inside the grid (172x125 or 86x250 mm)	850
1/3 page, inside the grid (172x90 or 62x250 mm)	600
SPECIAL POSITIONS	
Back cover	2,000
Page 3	1,900
Inside front cover	1,700
Opposite contents page	1600
Within contents page	1500
Single gatefold	2100
Double gatefold	2000 per page side
Facing colophon/advertisers list	1,600
Facing the "editor's letter"	1,500
Inside back cover	1,500
Requested placement (within the first 30 pages or according to the customer needs)	1,400
INSERTS	
2 pages	1,500
Every 2 additional pages	700
ADVERTORIALS	
Full page, well highlighted (conditions to be established with the editorial staff)	1,300

Different sizes are available on request

DISCOUNTS

From 2,500 to 4,000 euro	10%
From 4,001 to 6,000 euro	15%
Over 6,000 euro	20%

The quantity discounts cannot be summed up for different advertisers, even if managed by the same advertising agency. The agency commission (15%) is reserved only for acknowledged advertising agencies and is credited to them after payment of the advertisement by the customer. A 15% discount is granted to Amaplast and Assogomma Members, but, in this case, the agency commission is not reserved.

CLASSIFIED ADS

This specific space is available for companies or private individuals interested in trade services or business opportunities, vacant positions, materials, reconditioned or stock machinery and equipment.
The rate for each module (75x20 mm) is 50 euro + VAT.

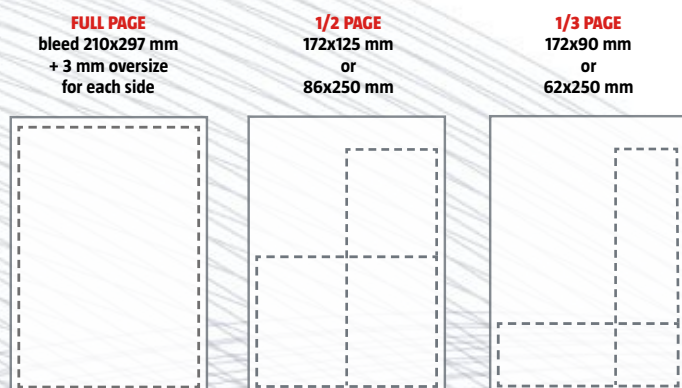

PRINTING MATERIAL

Printing material to be delivered on CD-R or transmitted by e-mail (g.zazzaro@macplas.it) within the dates mentioned in the editorial plan of page 5. The subject must be saved in CMYK, in the present sizes and formats, as high resolution (300 DPI) PDF format, with a 3-mm trim oversize in case of bleed ads. In order to avoid any possible objections, a printing proof (chromaline) for full colour ads with the CD-R is necessary. To be consistent with readers, the ads must be in the same language as the edition in which they are published (Italian, English, Russian, etc.). Exceptions must be agreed in advance with the editorial staff of MacPlas.

- **Inserts** (210x297 mm) must have trimming edge 10 mm up and 13 mm down, 2 mm left and 8 mm right. Paper weight must be between 135 and 175 g/m².
- **Sizes of flyers** must not exceed 200x275 mm.

MAILING

Our **MAILING SERVICE** (DEM) consists of sending an e-mail, completely customizable, from MacPlas account but on behalf of your company. If you are interested in using this service, you should provide a text in ZIP HTML format, including one or more links and possible images. We will tell you the number of readers who have downloaded the images and the number of readers who have clicked on links included in your communication. Mailing service for the whole mailing list has the following rates:

DEM to 20,000 Italian companies	1,800 euro
DEM to 30,000 worldwide companies	2,100 euro
2 DEM to Italian and English mailing lists	2,500 euro

MACPLAS ONLINE (www.macplas.it) is a real daily updated magazine authorized by the court of Milan. The table below describes the various formats available to advertisers to promote their activity and the 2025 rates for the English and Italian versions of the website.



Banner files can be delivered in one of the following formats: GIF, animated GIF, JPG or Flash. Flash files must include the destination URL.

MACPLAS ONLINE

STANDARD DIGITAL FORMATS

BANNER (MAX 100 KBYTE)	SIZE	EURO (VAT EXCL.)	LENGHT OF TIME
Top header (all pages)	1,230x130 pixels	800 €	1 month
Central banner (after the first news, only on the home page)	810x154 pixels	600 €	1 month
Side banner (below "most read news")	390x149 pixels	350 €	1 month
Side banner (above "most read news")	390x149 pixels	470 €	1 month
Skyscraper (all pages)	390x600 pixels	600 €	1 month

ADVERTORIAL

Written text (max 3,000 characters + 1-2 pictures (72 dpi, max width 500 pixels))	750 €	15 days
---	-------	---------

CLASSIFIED ADS AND JOB OFFERS

Written text (max 1,500 characters)	150 €	1 month
-------------------------------------	-------	---------

VIDEO FORMATS

Promotional pop up video It opens automatically without a click by the user, followed by scrolling on the page (in browsers which support this function) and it remains visible for 10 seconds.	1,000 €	1 month
Video interview with editor	900 €	30 days
Video interview with director (customized quotation)		
Video advertorial in a highlighted box. It can be opened by a click	850 €	15 days

MACPLAS ONLINE MOBILE VERSION

DIGITAL STANDARD FORMATS

BANNER (MAX 100 KBYTE)	SIZE	EURO (VAT EXCL.)	LENGHT OF TIME
Top header	1,230x130 pixel	200 €	1 month
Side banner (all pages)	390x149 pixel	150 €	1 month
VIDEO			
Video standard banner	390x149 pixel	200 €	1 month



MACPLAS E-NEWS

The Italian newsletter **MacPlas E-News** contains a selection of the news published on www.macplas.it and it is mailed twice a week (on Monday and Thursday) for about 20,000 Italian addresses, whilst the English version is sent once a week (on Wednesday) to 30,000 foreign addresses.

The readers of MacPlas E-News newsletters represent the beating heart of the plastics and rubber industry. The database, constantly updated and segmented, comprises primarily plastics and rubber processors, a category that constitutes the primary target for innovative technologies, services and solutions.

The profile of recipients extends strategically to manufacturers of machinery and equipment for processing, raw material and compound producers, research institutes and technological centres, specialised agents and distributors, design consultancies and technical advisory firms, as well as educational institutions and trade associations.

This controlled diversification ensures a comprehensive information ecosystem that covers the entire production supply chain, from raw materials to finished products, offering advertisers targeted opportunities and effective communication towards specific segments of the value chain.

Rates and sizes of banner ads are the following:



Files can be saved in GIF or JPG

MACPLAS E-NEWS

DIGITAL STANDARD FORMATS

BANNER (MAX 100 KBYTE)	DESCRIPTION	EURO (VAT EXCL.)	LENGHT OF TIME
Top header (all pages)	650x100 pixel	800 €	1 month
Central banner (after the first news)	650x68 pixel	750 €	1 month
Side banner (on the right)	295x113 pixel	470 €	1 month

ADVERTORIAL

Advertorial (first position)	text max 3,000 characters + 1-2 pictures (72 dpi, width max. 500 pixels)	450 €	1 newsletter
Advertorial (second position)	testo max 3000 caratteri + 1-2 foto (72 dpi, width max. 500 pixel)	1,200 €	4 newsletters
		300 €	1 newsletter
		900 €	4 newsletters

VIDEO FORMATS

Video Advertorial 1st position (placed in a highlighted box, it can be opened by a click)		550 €	1 newsletter
Video Advertorial 1st position (placed in a highlighted box, it can be opened by a click)		1,300 €	4 newsletters
Video Advertorial 2nd position (placed in a highlighted box, it can be opened by a click)		400 €	1 newsletter
Video Advertorial 2nd position (placed in a highlighted box, it can be opened by a click)		1,100 €	4 newsletters

Member discount
Amaplast
and Assogomma:
15%

Newsletters will not be published on the occasion of Italian holidays: from August 1 until August 31 and from December 23 until January 6

LINKEDIN

Since 2024, MacPlas' LinkedIn profile has been active, the digital channel that represents the evolution of the historic technical publication within the professional social media landscape. This dedicated space serves as a daily reference point for professionals, executives, technicians and enthusiasts in the plastics and rubber sector.

Users can access constant updates and exclusive insights on the leading companies in the plastics and rubber industry, with particular attention to innovative enterprises within the national and international landscape.

MacPlas' editorial team curates daily original content ranging from market analyses to presentations of new technologies. Particular focus is dedicated to technical and scientific curiosities, case studies and best practices that characterise an industry in constant evolution, from environmental sustainability to the circular economy, from Industry 4.0 automation to new frontiers in materials research.

Below is a list of advertising formats through which you can promote your company.

2026 ADVERTISING RATES

CAROUSEL	SIZE	EURO (VAT EXCL.)
Flipping presentation in the form of slides	text max 2000 chracters + 3-4 pictures	200,00 €
EDITORIAL CONTENT		
Company news presented with an exclsusive graphic template	text max 1000 chracters + 2-3 pictures	150,00 €
ANIMATED POST		
Text, pictures and company logo in a dynamic sequency	text max 300 chracters (slogan and key words) + 3-4 pictures e PNG logo	300,00 €
PROMOTIONAL VIDEO		
Video content created and provided by the company	mp4 file 1920x1080 pixel + destination URL	100,00 €

Any further requests will be agreed with the editorial staff.



FOLLOW US ON LINKEDIN

2026 EDITORIAL PLAN

MACPLAS ISSUE	MACHINES AND AUXILIARY EQUIPMENT	TRADE FAIRS	DEADLINE FOR EDITORIALS	DEADLINE FOR AD MATERIALS
410 January/February	Blow moulding machines Screws and cylinders Robots and manipulators	Mecspe, March 4-6, 2026 Bologna	28/11/2025	08/01/2026
411 March/April	Recycling and compounding plants Machining centres Automation systems and devices	SPS Italia, May 26-28, 2026 Parma	30/01/2026	27/02/2026
412 May/June	Printing and decoration machines Moulds for injection moulding, blow moulding and thermoforming Instrumentation for analysis, testing and process and laboratory measurements	Plast June 9-12, 2026 Milan	13/03/2026	24/04/2026
413 July/August	Extrusion lines Foam processing machines Welding systems		29/05/2026	26/06/2026
414 September/October	Rotational moulding machines Filtration systems Thermoforming plants	Ecomondo, November 4-7, 2026 Rimini Fakuma, October 12-16, 2026 Friedrichshafen	26/06/2026	31/07/26
415 November/December	Injection moulding machines Transport, feeding, dosing and mixing systems Thermoregulation and refrigeration plants and systems		02/10/2026	30/10/2026

MACPLAS INTERNATIONAL	MACHINES AND AUXILIARY EQUIPMENT	TRADE FAIRS	DEADLINE FOR EDITORIALS	DEADLINE FOR AD MATERIALS
MacPlas International May 2026 (in English)	Recent innovations in processing technologies and auxiliary equipment with a particular focus on solutions presented at Plast 2026	Plast June 9-12, 2026, Milan	13/03/2026	24/04/2026
MacPlas International October 2026 (in English)	Recent innovations in processing technologies and auxiliary equipment with a particular focus on solutions presented at Fakuma 2026	Fakuma, October 12-16, 2026, Friedrichshafen	03/07/2026	31/07/2026

Editorial topics, distribution trade shows and delivery dates of editorials and advertisements listed in this price list are indicative only and may change according to the needs of the editorial team. The delivery of editorials and advertisements is the responsibility of the companies. The editorial team cannot be held responsible for the failure to receive advertisements and editorials by the mentioned and/or contractual deadlines and reserves the right to assess the suitability for publication and to schedule the publication of editorials and advertisements received.

The magazines in Italian are published approximately between the last week of the first month and the first week of the second month of each issue's cover. The international editions are published in time for shipment to the relevant trade fairs according to the editorial plan.

THEY HAVE CHOSEN MACPLAS

ALFATEST • ALPHAMAC • AMUT • ARBURG • JEC • JOHNSON FLUITEN • KISTLER • KRAIBURG TPE
ASAHI KASEI • BANDERA • BARUFFALDI PLASTIC • KUNSTSTOFF- UND FARBEN • MAAG • MACCHI •
TECHNOLOGY • BATTENFELD - CINCINNATI GERMANY • MAGIC MP • MAIN TECH • MARIS • MAST • MAYR • MD
• BAUSANO • BD PLAST FILTERING SYSTEMS • BFM • PLAST • MECCANOPLASTICA • MERO • MITO POLIMERI
BIESSE • BINOVA • BIOPLASTICS MAGAZINE • BMB • • MIXACO • MIXRON • MORETTO • MOVING • NEGRI
BREAK MACHINERY • BRUKER ITALIA UNIPERSONALE • BOSSI • OMSO • PET DAY • PET SOLUTIONS • PETCORE
• CALDARA PLAST • CAMPETELLA ROBOTIC EUROPE • PIOVAN • PLAS MEC • PLAST EURASIA
CENTER • CERESANA RESEARCH • • PLASTEX • PLASTIBLOW • PLASTIC
CHIMAR • CHINAPLAS • CMG **MACPLAS** SYSTEMS • PLASTORE • PRESMA •
• CMS • COLINES • COMERIO PREVIERO • PROHEMA • PROFILE
ERCOLE • COTTRIL • COVESTRO DIES • PRSE - PLASTICS RECYCLING
• DGTS • DISTRUPOL • SHOW EUROPE • PSM CELADA
ECOMONDO • ELESA • ENERGIA FASTENERS • QUARZWERKE - HPF
EUROPA • EREMA • EUROMAP • MINERALS • RADICIGROUP • ROBOLINE •
EUROPOLIURETANI • EUROVITI • EXACT • EXPO SARA • SGC • SICA • SIEMENS • SIKORA • SIRMAX •
PLASTICOS • FAP • FB BALZANELLI • FIMIC • FRIGEL SITRA • SKZ - KFE • SPS ITALIA • STAR AUTOMATION
FIRENZE • GAMMA MECCANICA • GAMMA STAMPI • EUROPE • TECHNOBINS • TECNO SYSTEM •
GEFIT • GEFRAN • GIBITRE INSTRUMENTS • GIMATIC TECNOMATIC • TECNOVA • TRIA • TROOSTWIJK •
• GIURGOLA STAMPI • GNEUSS • GRAFE • HELIOS ULTRA SYSTEM • UNION • UNITECHEM • VANETTI •
ITALQUARTZ • HERBOLD MECKESHEIM • HOLONIX • VINYLPLUS SUSTAINABILITY FORUM • WITTMANN
HS-UMFORMTECHNIK • HUSKY • ICMA SAN GIORGIO BATTENFELD ITALIA • WM THERMOFORMING
• IIP • IMG • INGLASS • IPM • ITIB MACHINERY • MACHINES SA • ZAMBELLO • ZEON EUROPE



STAFF

Managing director:
Mario Maggiani
m.maggiani@promaplast.org

Editor in chief:
Luca Mei
l.mei@macplas.it

Editorial staff:
Giampiero Zazzaro
g.zazzaro@macplas.it

Editorial assistant:
Alice Polimeno
segreteria@macplas.it

AGENTS FOR ADVERTISING

Roberta Pagan (ITALY)
Tel.: (+39) 02 82283747
Cell.: (+39) 393 6772295
r.pagan@macplas.it

Martina Lerner (EU sales office)
Tel.: (+49) 6226 971515
lerner-media@t-online.de

PUBLISHING HOUSE: PROMAPLAST SRL
Centro Direzionale Milanofiori - Palazzo F/3
20057 Assago (MI)
Tel.: (+39) 02 82283735
Fax: (+39) 02 57512490
macplas@macplas.it
www.macplas.it