

MP3

2024 Mediakit

MAGAZINE

MacPlas, the most read in Italy
mailed to 7,000 companies

WEBSITE

MacPlas Online, e-magazine
for the global plastics
and rubber industry

- News and classified ads
- Trade shows and sectoral events
- Banner ads

NEWSLETTER

MacPlas E-News, reaching
over 30,000 specialized
players worldwide,
both in Italian and
English editions

For a free subscription click on
www.macplas.it

MACPLAS

MP
ELASTICA

RIVISTA DELLE MATERIE PLASTICHE E DELLA GOMMA

tori italiani:
> 2021 positivo e inizio
incoraggiante

plast i protagonisti
lo meccanico delle plastiche

ormatura: il piacere di tenere in allenam
rie competenze

za del paziente e sostenibilità
ballaggi farmaceutici

Associated with:



In 2023 the average circulation of each issue of MacPlas was about 7,000 copies.

The technical magazine MacPlas is distributed to companies operating in different segments of the plastics and rubber industry. The circulation for each issue of the Italian edition, on the basis of readers' activity, is the following:

Italian plastics and rubber processors and recyclers (injection moulding and related processes 52%, extrusion 31%, blow moulding 5%, thermoforming 5%, others 7%)	5,500
Manufacturers and representatives of machinery & equipment (including Amaplast Members)	700
Producers of raw materials and additives	300
Others (retailers, agents etc.)	300
Abroad (chambers of commerce, associations etc.).	200
Total average circulation	7,000

MACPLAS INTERNATIONAL

Some special supplements (in local language) are scheduled concurrently with the most important specialized fairs worldwide, that often host collective participations of Italian exhibitors.

MACPLAS INTERNATIONAL
MP
 THE MAGAZINE FOR THE PLASTICS AND RUBBER INDUSTRY



Massimo Margaglione is the new president of Amaplast

MACPLAS
MP
 ELASTICA
 MATERIE PLASTICHE E DELLA GOMMA



Uno sguardo a tutto tondo sulla meccanica strumentale

La sostenibilità tra economia e rapporti fiduciari

Quando l'arte diventa welfare aziendale

Riciclo chimico, selezione per la transizione ecologica

Two issues of the electronic version of MacPlas are sent **OF CHARGE** to the subscribers of MacPlas (paper edition). The complete archive, starting from 2008, of the electronic version of MacPlas is available for subscribers to the electronic version.

ANNUAL SUBSCRIPTIONS

MACPLAS (Italian paper edition - 6 issues)

40 euro + VAT for Italy

60 euro

MACPLAS (electronic browsable edition)

25 euro + VAT

MacPlas (Italian paper + electronic browsable edition)

50 euro + VAT for Italy

70 euro

2024 ADVERTISING RATES

SIZES (full color)	EURO (VAT excluded)
Full colour, bleed (210x297 mm + 3 mm oversize for each side)	1,300
1/2 page, inside the grid (172x125 or 86x250 mm)	850
1/3 page, inside the grid (172x90 or 62x250 mm)	600
SPECIAL POSITIONS	
Back cover	2,000
Page 3	1,900
Inside front cover	1,700
Facing colophon / advertisers list	1,600
Facing the "editor's letter"	1,500
Inside back cover	1,500
Requested placement (within the first 30 pages or according to the customer needs)	1,400
ELASTICA SPONSORS	
Box with logo (58x62,5 mm)	600 for one year
INSERTS	
2 pages	1,500
Every 2 additional pages	700
ADVERTORIALS	
Full page, well highlighted (conditions to be established with the editorial staff)	1,300

Different sizes are available on request

DISCOUNTS

From 2,500 to 4,000 euro	10%
From 4,001 to 6,000 euro	15%
Over 6,000 euro	20%

The quantity discounts cannot be summed up for different advertisers, even if managed by the same advertising agency. The agency commission (15%) is reserved only for acknowledged advertising agencies and is credited to them after payment of the advertisement by the customer. A 15% discount is granted to Amaplast and Assogomma Members, but, in this case, the agency commission is not reserved.

CLASSIFIED ADS

This specific space is available for companies or private individuals interested in trade services or business opportunities, vacant positions, materials, reconditioned or stock machinery and equipment. **The rate for each module (75x20 mm) is 50 euro + VAT.**

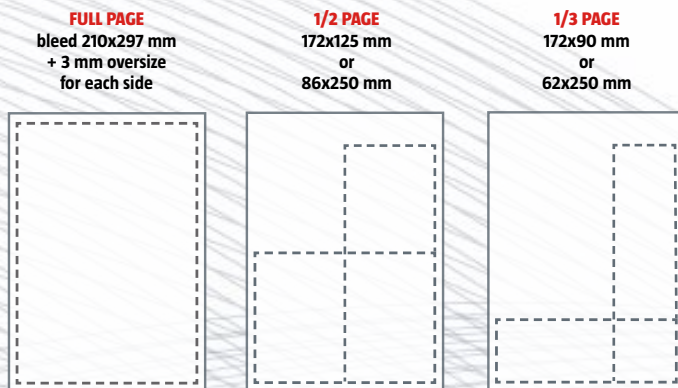

PRINTING MATERIAL

Printing material to be delivered on CD-R or transmitted by e-mail (g.zazzaro@macplas.it) within the dates mentioned in the editorial plan of page 5. The subject must be saved in CMYK, in the present sizes and formats, as high resolution (300 DPI) PDF format, with a 3-mm trim oversize in case of bleed ads. In order to avoid any possible objections, a printing proof (chromaline) for full colour ads with the CD-R is necessary. To be consistent with readers, the ads must be in the same language as the edition in which they are published (Italian, English, Russian, etc.). Exceptions must be agreed in advance with the editorial staff of MacPlas.

- **Inserts** (210x297 mm) must have trimming edge 10 mm up and 13 mm down, 2 mm left and 8 mm right. Paper weight must be between 135 and 175 g/m².
- **Sizes of flyers** must not exceed 200x275 mm.

MAILING

Our **MAILING SERVICE** (DEM) consists of sending an e-mail, completely customizable, from MacPlas account but on behalf of your company. If you are interested in using this service, you should provide a text in ZIP HTML format, including one or more links and possible images. We will tell you the number of readers who have downloaded the images and the number of readers who have clicked on links included in your communication. Mailing service for the whole mailing list has the following rates:

DEM to 20,000 Italian companies	1,800 euro
DEM to 30,000 worldwide companies	2,100 euro
2 DEM to Italian and English mailing lists	2,500 euro

With its recently renewed graphics, **MACPLAS ONLINE** (www.macplas.it) is a real daily updated magazine authorized by the court of Milan.

The table below describes the various formats available to advertisers to promote their activity and the 2024 rates for the English and Italian versions of the website.



Banner files can be delivered in one of the following formats: GIF, animated GIF, JPG or Flash. Flash files must include the destination URL.

MACPLAS ONLINE

STANDARD DIGITAL FORMATS

BANNER (MAX 100 KBYTE)	SIZE	EURO (VAT EXCL.)	LENGTH OF TIME
Top header (all pages)	1,230x130 pixels	800 €	1 month
Central banner (after the first news, only on the home page)	810x154 pixels	600 €	1 month
Side banner (below "most read news")	390x149 pixels	350 €	1 month
Side banner (above "most read news")	390x149 pixels	470 €	1 month
Skyscraper (all pages)	390x600 pixels	600 €	1 month

ADVERTORIAL

Written text (max 3,000 characters + 1-2 pictures (72 dpi, max width 500 pixels))	750 €	15 days
---	-------	---------

CLASSIFIED ADS AND JOB OFFERS

Written text (max 1,500 characters)	150 €	1 month
-------------------------------------	-------	---------

VIDEO FORMATS

Promotional pop up video It opens automatically at the first access to the site without a click by the user, followed by scrolling on the page (in browsers which support this function) and then it remains fixed in the right column as the first banner	800 €	1 month
Video interview with editor	900 €	30 days
Video interview with director (customized quotation)		
Video advertorial in a highlighted box. It can be opened by a click	850 €	15 days

MACPLAS ONLINE MOBILE VERSION

DIGITAL STANDARD FORMATS

BANNER (MAX 100 KBYTE)	SIZE	EURO (VAT EXCL.)	LENGTH OF TIME
Top header	1,230x130 pixel	200 €	1 month
Side banner (all pages)	390x149 pixel	150 €	1 month

VIDEO

Video standard banner	390x149 pixel	200 €	1 month
-----------------------	---------------	-------	---------

MACPLAS E-NEWS

DIGITAL STANDARD FORMATS

BANNER (MAX 100 KBYTE)	DESCRIPTION	EURO (VAT EXCL.)	LENGTH OF TIME
Top header (all pages)	1,230x130 pixel	800 €	1 month
Central banner (after the first news)	810x154 pixel	750 €	1 month
Side banner (on the right)	390x149 pixel	470 €	1 month

ADVERTORIAL

Advertorial (first position)	text max 3,000 characters + 1-2 pictures (72 dpi, width max. 500 pixels)	450 €	1 newsletter
		1,200 €	4 newsletters
Advertorial (second position)	testo max 3000 caratteri + 1-2 foto (72 dpi, width max. 500 pixel)	300 €	1 newsletter
		900 €	4 newsletters

VIDEO FORMATS

Video Advertorial 1 st position (placed in a highlighted box, it can be opened by a click)	550 €	1 newsletter
Video Advertorial 1 st position (placed in a highlighted box, it can be opened by a click)	1,300 €	4 newsletters
Video Advertorial 2 nd position (placed in a highlighted box, it can be opened by a click)	400 €	1 newsletter
Video Advertorial 2 nd position (placed in a highlighted box, it can be opened by a click)	1,100 €	4 newsletters

Newsletters will not be published on the occasion of Italian holidays: from August 1 until August 31 and from December 23 until January 6

Member discount
Amaplast
and Assogomma:
15%

Files can be saved in GIF or JPG

MACPLAS E-NEWS

The Italian newsletter **MacPlas E-News** contains a selection of the news published on www.macplas.it and it is mailed twice a week (on Monday and Thursday) to about 20,000 Italian addresses, whilst the English version is sent once a week (on Wednesday) to 30,000 foreign addresses.

Most of readers are plastics and rubber processors, but also machinery manufacturers, producers of raw materials, research institutes, agents etc... Rates and sizes of banner ads are the following:

2024 EDITORIAL PLAN

MACPLAS ISSUE	MACHINERY & ANCILLARY EQUIPMENT	TRADE FAIRS	DEADLINE FOR EDITORIALS	DEADLINE FOR AD MATERIALS	PUBLICATION
399 February/ March	Injection moulding Drying and dehumidification Robots and manipulators	Mecspe 2024 Bologna	08/01/2024	29/01/2024	23/02/2024
400 April/ May	Blow moulding Belling machines and corrugators Recycle and compounding	SPS Italia 2024 Parma	11/03/2024	01/04/2024	03/05/2024
401 June/ July	Extrusion Machining centres Moulds and hot runners		22/04/2024	15/05/2024	14/06/2024
402 August/ September	Rotational moulding Measurement and control Filtration systems and granulators	Fakuma 2024 Friedrichshafen	10/06/2024	01/07/2024	26/07/2024
403 October/ November	Thermoforming machines Mixing and dosing Conveying and feeding system	Ecomondo 2024 Rimini	16/09/2024	07/10/2024	04/11/2024
404 October/ November	Welding and printing machines Cylinders and screws Automation		04/11/2024	25/11/2024	20/12/2024

MACPLAS INTERNATIONAL	MACHINERY & ANCILLARY EQUIPMENT	TRADE FAIRS	DEADLINE FOR EDITORIALS	DEADLINE FOR AD MATERIALS	PUBLICATION
MacPlas International April 2024 (in Chinese)	Recent innovations in processing technology and auxiliary equipment with special focus on solutions presented at Chinaplas 2024	Chinaplas 2024 Shanghai	19/02/2024	04/03/2024	29/03/2024
MacPlas International September 2024 (in English)	Recent innovations in processing technology and auxiliary equipment with special focus on solutions presented at Fakuma 2024	Fakuma 2024 Friedrichshafen	21/08/2024	11/09/2024	01/10/2024

Editorial topics, distribution trade shows and delivery dates of editorials and advertisements listed in this price list are indicative only and may change according to the needs of the editorial team. The delivery of editorials and advertisements is the responsibility of the companies. The editorial team cannot be held responsible for the failure to receive advertisements and editorials by the mentioned deadlines and reserves the right to assess the suitability for publication and to schedule the publication of editorials and advertisements received.

THEY HAVE CHOSEN MACPLAS

ALFATEST • ALLOD WERKSTOFF • ALPHAMAC • AMAPLAST • AMIS MASCHINEN-VERTRIEBS • AMUT • ARBURG • AUVERGNE RHONE ALPES ENTREPRISE • BANDERA • BARUFFALDI PLASTIC TECHNOLOGY • BAUSANO & FIGLI • BD PLAST FILTERING SYSTEMS • BFM • BIESSE • BINOVA • BMB • BREAK MACHINERY • BRUKER ITALIA • BUNTING NEWTONG • BUSS • CALDARA PLAST • CAMPETELLA ROBOTIC CENTER • CHIMAR • CHINAPLAS 2023 • CM PRODUZIONE • CMG spa • CMP • CMS • COLINES • COMAC • COMERIO ERCOLE • COMI • CONTROL TECHNIQUES • COVESTRO • DGTS • ECOMONDO 2023 • ELESA • ELITE PLUS • ENGEL • ENYAX • EREMA • ERHARDT+ LEIMER • EUROVITI • EXACT • FAKUMA 2023 • FB BALZANELLI • FIMIC • FRIUL FILIERE • GAMMA STAMPI • GEFIT • GEFRAN • GIBITRE INSTRUMENTS • GIMATIC • GLOBAL ACCELERATIONIST COMPANY • GNEUSS • GRAFE • HELIOS ITALQUARTZ • HENKEL • HS-UMFORMTECHNIK • HUSKY • IMG • INGLASS • IPE - INNOVATION POLYMER ENGINEERING • IPM • IPS - INTELLIGENT PELLETIZING SOLUTIONS C/O ALESSANDRO MAZZA • ITIB • JEC 2023 • KAUTEX • KEYCYCLE • LABORPLAST • LANXESS • LASERPOINT • LAWER • LINK INTERNATIONAL • LK IMM • MAAG • MACCHI • MARFRAN • MARIS • MAST • MATICS • MAYR ITALIA • MD PLAST • MDC • MERO • MING JILEE ENTERPRISE • MITO POLIMERI • MOOG ITALIANA • NEGRI BOSSI • NETZSCH • NIDEC INDUSTRIAL AUTOMATION • OC OERLIKON • OMSO • PACKAGING SPEAKS GREEN • PEGASO INDUSTRIES • PIOVAN • PLAS MEC • PLAST 2023 • PLAST EURASIA 2023 • PLASTIBLOW • PLASTIMAGEN 2023 • PLASTORE • POLYNT • PRESMA • PREVIERO • PROCHEMA • PROFILE DIES • RADICI NOVACIPS • REP ITALIANA • RIMA TEAM • RIPRESS • ROBOLINE • RODOLFO COMERIO • SARA • SBS • SIKORA • SIPOLE • SIRIUS ELECTRIC • SIRMAX • SISE SMITHERS RAPRA • SONDERHOFF • SPS ITALIA 2023 • STAR AUTOMATION EUROPE • SVERITAL • TECNO SYSTEM • TECNOMATIC • TIRE TECHNOLOGY 2023 • TOTALENERGIES • TROOSTWIJK AUCTION • ULTRA SYSTEM • UNITECHEM • VANETTI • VISION ENGINEERING • WAMGRUOP • ZAMBELLO RIDUTTORI • ZEON EUROPE

MACPLAS



STAFF

Managing director:
Mario Maggiani
m.maggiani@promaplast.org

Editor: Luca Mei
l.mei@macplas.it

Editorial assistant:
Giampiero Zazzaro
g.zazzaro@macplas.it

AGENT FOR ADVERTISING

Martina Lerner
(EU sales office)
Lerner-media@t-online.de

PUBLISHING HOUSE: PROMAPLAST SRL
Centro Direzionale Milanofiori - Palazzo F/3
20057 Assago (MI)
Tel.: (+39) 02 82283735
Fax: (+39) 02 57512490
macplas@macplas.it -
www.macplas.it